

REV. NO.	DESCRIPTION	REVISIONS	DATE

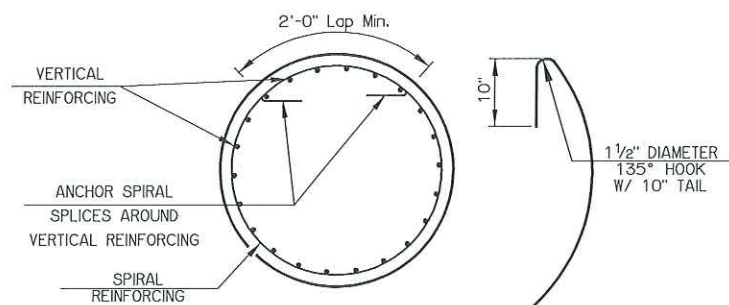

SPIRAL REINFORCING SPLICE DETAIL

NOTE: SPIRAL BAR LENGTH QUANTITY DOES NOT INCLUDE LAP. IF LAP IS REQUIRED, THE LENGTH OF THE LAP SHALL BE AS SHOWN.

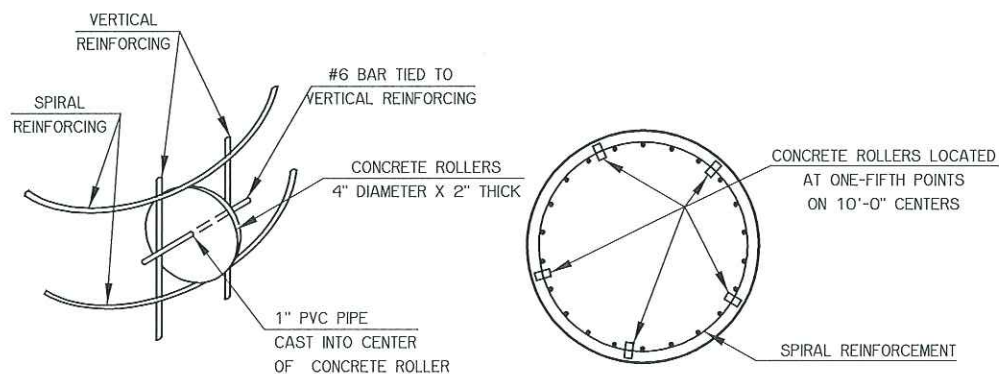

ROLLER INSTALLATION

ROLLER PLACEMENT

DETAIL OF CONCRETE ROLLERS

NOTE: CONCRETE USED IN THE CONCRETE ROLLERS SHALL HAVE A MINIMUM 28 DAY COMPRESSIVE STRENGTH OF 4,000 P.S.I. SLAB BOLSTERS, HIGH CHAIRS, AND PLASTIC ROLLERS SHALL NOT BE SUBSTITUTED FOR THE CONCRETE ROLLERS.

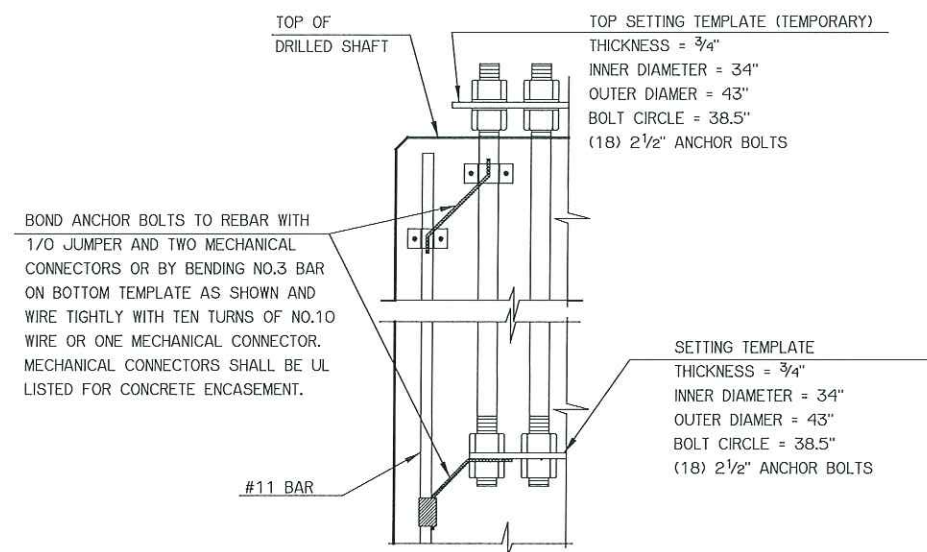

ANCHOR BOLT TEMPLATE AND LIGHTING PROTECTION SYSTEM

MONOTUBE STRUCTURE (DRILLED SHAFT DETAILS) (SHEET 3 OF 3)		Design	JG	JW
		Detail	JG	JW
		Check	JG	JW
		Squad Eng.	SUPERVISOR	ENGINEER
STATE OF OKLAHOMA		DEPARTMENT OF TRANSPORTATION		JOB PIECE NO. 32625(04)
				SHEET NO. M7